



SJIII 3215 | SJIII 3219 DC ELECTRIC SCISSOR LIFTS

Skyjack's Compact DC Electric Scissor Lifts offer Skyjack's easy to service, low maintenance design in a compact and versatile package. Equipped with variable speed front wheel hydraulic drive, and 90° steering, both models are capable of maneuvering in the smallest spaces. Featuring a 0.91 m roll out extension deck, these models offer work heights up to 7.79 m. Both platforms boast an industry leading capacity 227 kg.

The SJIII 3215 and SJIII 3219 feature durable steel swing-out component trays, providing unrestricted access for easy maintenance and service. Skyjack's DC Electric Scissor lifts utilize Skyjack's standard colour coded and numbered wiring system with analog based controls.



SKYJACK™

DC ELECTRIC SCISSOR LIFTS

SPECIFICATIONS

SJIII 3215

SJIII 3219

AS/NZS 1418.10:2011

A Work Height	6.57 m	7.79 m
B Raised Platform Height	4.57 m	5.79 m
C Lowered Platform Height	0.88 m	0.99 m
D Overall Width	0.81 m	0.81 m
E Overall Length	1.78 m	1.78 m
F Stowed Height (Rails Up)	1.88 m	1.99 m
G Stowed Height (Rails Down)	1.53 m	1.64 m
H Platform Width (Inside Dimension)	0.66 m	0.66 m
I Platform Length (Inside Dimension)	1.63 m	1.63 m
Extension Deck (Roll Out)	0.91 m	0.91 m
Ground Clearance (Stowed)	6.03 cm	6.03 cm
Ground Clearance (raised)	1.78 cm	1.78 cm
Wheelbase	1.40 m	1.40 m
Weight	1120 kg	1579 kg
Gradeability	25%	25%
Turning Radius (Inside)	0	0
Turning Radius (Outside)	1.68 m	1.68 m
Lift Time (With Rated Load)	22 sec	21 sec
Drive Speed (Stowed)	3.7 km/h	3.2 km/h
Drive Speed (Raised)	1.1 km/h	1.1 km/h
Maximum Drive Height	Full Height	Full Height
Capacity (Overall)	227 kg	227 kg
Maximum # of Persons (0 wind rating)	2	2
Maximum # of Persons (12.5 m/sec wind rating)	1	1

STANDARD FEATURES

- Drivable at full height
- Variable speed, front two wheel hydraulic drive
- 90° steering (zero inside turning radius)
- Wet disc SAHR brakes
- Proportional controls for drive & lift functions
- 0.91 m roll out extension deck
- 24V DC power source
- Low voltage battery protection
- 25% gradeability
- Solid rubber, non-marking tyres
- Pothole protection system
- Wiring for AC outlet on platform
- Tilt alarm with drive & lift cut-out
- All motion audible alarm
- Overload sensing system
- Lowering warning system
- Lanyard attachment points
- Operator horn
- Half height spring hinged gate
- Forklift pockets and tie down/lift lugs
- Analog control system
- Colour coded and numbered wiring system

OPTIONS†

- Flashing light
- Dual flashing lights
- Shop airline to platform
- 250 Ah batteries
- Hinged railing system
- Full height spring hinged gate*

*not available with hinged railing system

‡ Capacities, and machine weights may differ when options are added

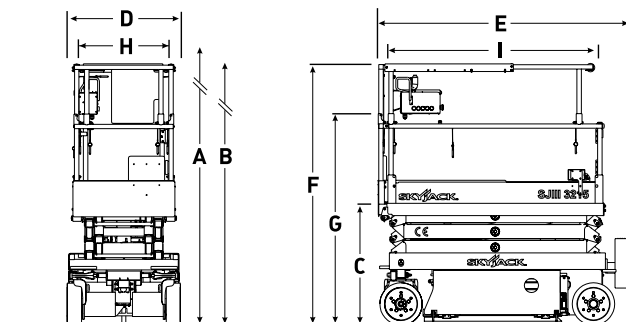

Skyjack Australia Pty Ltd

4 Coates Place
Wetherill Park
New South Wales, 2164
Tel: +61 (0) 2878 63200
Fax: +61 (0) 2878 63222
Email: jcranmer@skyjack.com

www.skyjack.com



SKYJACK™

This brochure is for illustrative purpose only and based on the latest information at the time of printing. Skyjack Inc. reserves the right to make changes at any time, without notice, to specifications, standard and optional equipment. Consult the Operating Maintenance and Parts Manuals for proper procedures. AS marked platforms are in conformance to Standard AS/NZS 1418.10:2011.