



SJ6826 RT | SJ6832 RT **ROUGH TERRAIN SCISSOR LIFTS**

The SJ6826 RT and SJ6832 RT both come equipped with an exclusive cross over symmetrical 4WD system for superior traction. Featuring up to 50% gradeability, these machines can meet the needs of the most challenging job site terrain. Standard features also include an easy to use 1.52 m roll out extension deck, which can be secured in multiple positions for increased platform space and improved reach capabilities. Both models are drivable at full height with the roll out deck fully extended. A low stowed height is ideal for loading and unloading tools and materials.

Consistent with Skyjack's robust and reliable design features, the Rough Terrain Scissor Lifts utilize Skyjack's standard colour coded and numbered wiring system with analog based controls.



SKYJACK[™]

ROUGH TERRAIN SCISSOR LIFTS

SPECIFICATIONS

SJ6826 RT

SJ6832 RT

AS/NZS 1418.10:2011

A Work Height	9.92 m	11.75 m
B Raised Platform Height	7.92 m	9.75 m
C Lowered Platform Height	1.23 m	1.37 m
D Overall Width	1.72 m	1.72 m
E Overall Length	3.35 m	3.35 m
F Stowed Height (Rails Up)	2.37 m	2.51m
G Stowed Height (Rails Down)	1.61 m	1.75 m
H Platform Width (Inside Dimension)	1.42 m	1.42 m
I Platform Length (Inside Dimension)	2.44 m	2.44 m
Deck Extension	1.52 m	1.52 m
Ground Clearance	0.20 m	0.20 m
Wheelbase	2.04 m	2.04 m
Weight	3305 kg	3655 kg
Gradeability	50%	40%
Turning Radius (Inside)	1.52 m	1.52 m
Turning Radius (Outside)	3.96 m	3.96 m
Lift Time (With Rated Load)	36 sec	39 sec
Drive Speed (Stowed)	6.1 km/h	6.1 km/h
Drive Speed (Raised)	0.6 km/h	0.6 km/h
Maximum Drive Height	Full Height	Full Height
Capacity (Overall)	454 kg	454 kg
Maximum # of Persons	4	4
Maximum # of Persons (12.5 m/sec wind rating)	4	2

STANDARD FEATURES

- Crossover symmetrical 4WD
- Drivable at full height with roll out deck fully extended
- Independent/auto leveling outriggers
- 1.52 m roll out extension deck
- Diesel engine
- 90° swing out engine tray
- Multiple wet disc SAHR brakes
- Wiring for AC outlet on platform
- Up to 40% gradeability (6826 RT)
- Tilt alarm with drive & lift cut-out
- All motion audible alarm
- Overload sensing system
- Lowering warning system
- Lanyard attachment points
- Operator horn
- Hinged railing system
- Forklift pockets and tie down/lift lugs
- Full height spring hinged gate at rear of unit
- Analog control system
- Colour coded and numbered wiring system
- 26 x 12 low profile grip lug foam-filled tyres

OPTIONS‡

- Diesel scrubber
- Flashing light
- Shop airline to platform
- Cold weather start package (Includes hydraulic oil tank heater, battery blanket, block heater)
- Foam-filled non-marking tyres (6826RT only)
- Solid non-marking tyres

‡ Capacities, and machine weights may differ when options are added

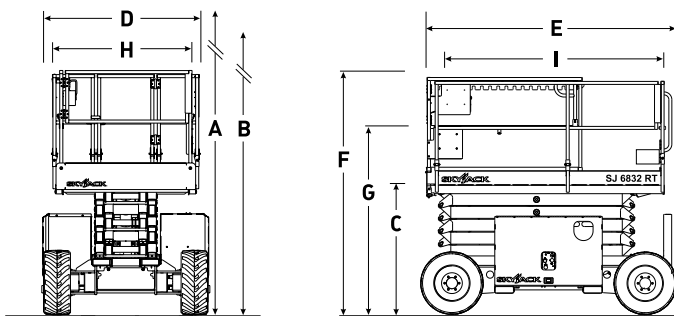

Skyjack Australia Pty Ltd

4 Coates Place
Wetherill Park
New South Wales, 2164
Tel: +61 (0) 2878 63200
Fax: +61 (0) 2878 63222
Email: jcranmer@skyjack.com

www.skyjack.com



SKYJACK™

This brochure is for illustrative purpose only and based on the latest information at the time of printing. Skyjack Inc. reserves the right to make changes at any time, without notice, to specifications, standard and optional equipment. Consult the Operating Maintenance and Parts Manuals for proper procedures. AS marked platforms are in conformance to Standard AS/NZS 1418.10:2011.

AU/NZ/04/2013